

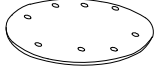





**LISTADO DE PIEZAS  
COMPOSANTS  
PARTS LIST**

|   |   |       |   |   |      |   |   |       |
|---|---|-------|---|---|------|---|---|-------|
| 1 |  | 1 PC  | 2 |  | 1 PC | 3 |  | 2 PCS |
| 4 |  | 2 PCS |   |   |      |   |   |       |

**HERRAJES  
QUINCALLERIE  
HARDWARE**

|   |   |      |   |   |        |   |   |        |
|---|---|------|---|---|--------|---|---|--------|
| A |  | 1 PC | D |  | 12 PCS | E |  | 12 PCS |
|   |   |      |   |   |        |   |   |        |

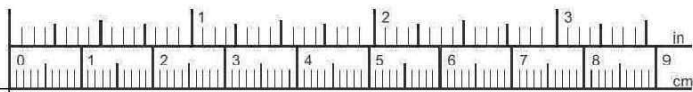

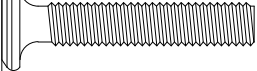
**B** X12  M6 X 35MM (RB)

**C** X8  M6 X 25MM (RB)

# STEP 1/ ETAPE 1

EN: Remove 2 JCBC screw at the mounting plate first.  
 ES: Retirar los 2 tornillos JCBC antes de iniciar el montaje de la tapa.  
 FR: Retirer les 2 vis JCBC avant de procéder au montage du plateau.

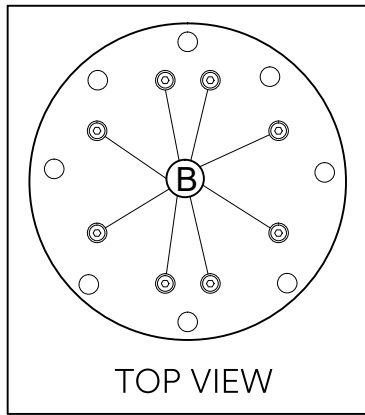
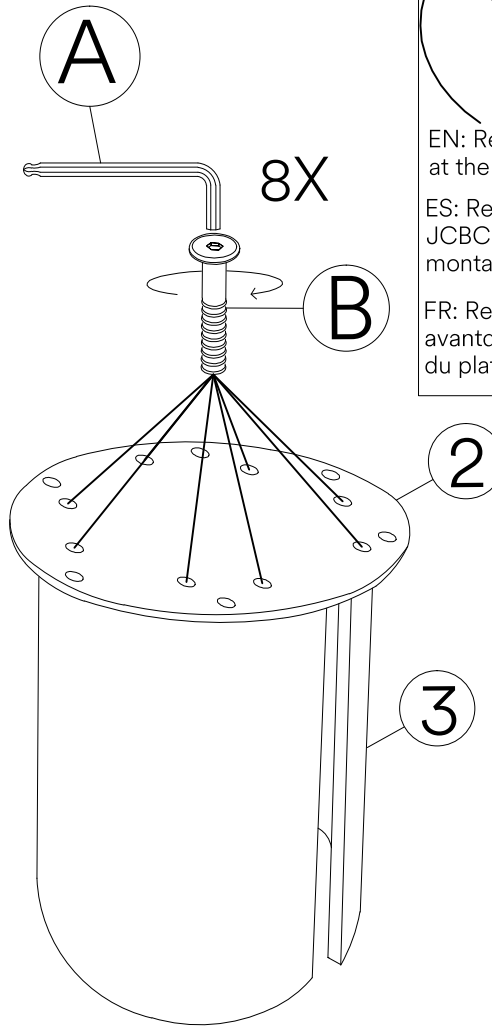

|   |  |       |
|---|--|-------|
| A |  | 1 PC  |
| B |  | 8 PCS |

M6 X 35MM (R8)

# STEP 2/ ETAPE 2

SPANISH :  
 En caso de reclamación, por favor, facilitar la información escrita en la etiqueta.  
 FRENCH :  
 En cas de réclamation, merci de transmettre les informations contrnues sur l' étiquette fixée sur le produit.  
 ENGLISH :  
 If you may have whatever complaint, please, let us know the information written on the label.

|   |  |       |
|---|--|-------|
| A |  | 1 PC  |
| C |  | 8 PCS |
| D |  | 8 PCS |
| E |  | 8 PCS |



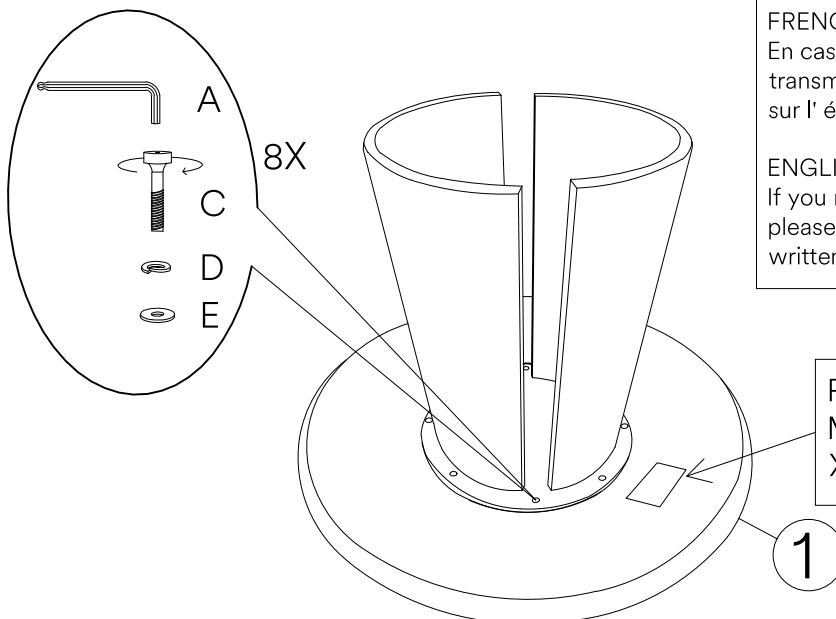

M6 X 25MM (R8)

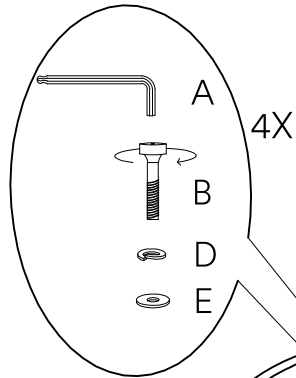

PI : XXX  
 Model: YYY  
 XXX

# STEP 3/ ETAPE 3



|   |   |       |
|---|---|-------|
| A |                    | 1 PC  |
| B | <br>M6 X 35MM (RB) | 4 PCS |
| D |                    | 4 PCS |
| E |                    | 4 PCS |

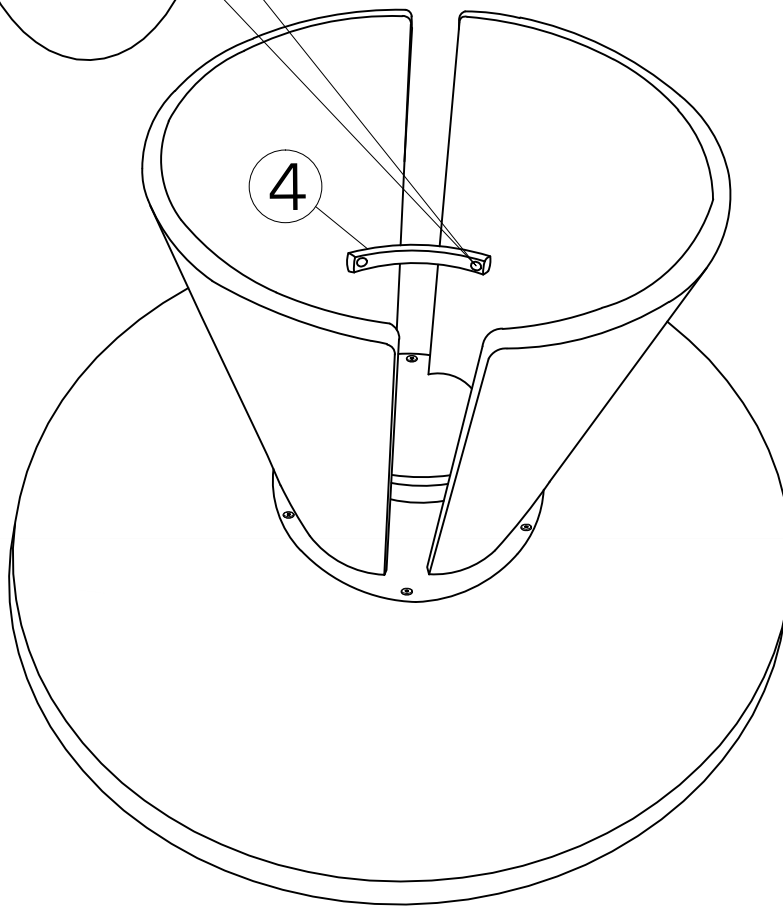

PRODUIT MONTÉ

